

BS5163 NRS Metallic seated Gate valve

SPECIFICATIONS

Size	DN 40 - 300
Class	PN 10 - PN 16
Design	BS 5163
Face to Face	BS 5163 / ISO 5752 3 Series
End Flange	BS 4504 / BS EN 1092
Test	BS 5163

STANDARD MATERIALS OF MAIN PARTS

ITEM	PART NAME	MATERIAL
1	Body	Ductile Iron
2	Wedge	Ductile Iron
3	Bonnet	Ductile Iron
4	Stem	Stainless Steel 420/431/316
5	Stem Nut	Brass
6	Holding Ring	Brass
7	Sealing Ring	Brass
8	Body Ring	Brass/Bronze
9	Wedge Ring	Brass/Bronze
10	Gland	Ductile Iron
11	Handwheel	Ductile Iron
12	Bonnet Gasket	NBR
13	O Ring	NBR
14	Dust Ring	NBR
15	Bol t	Stainless steel

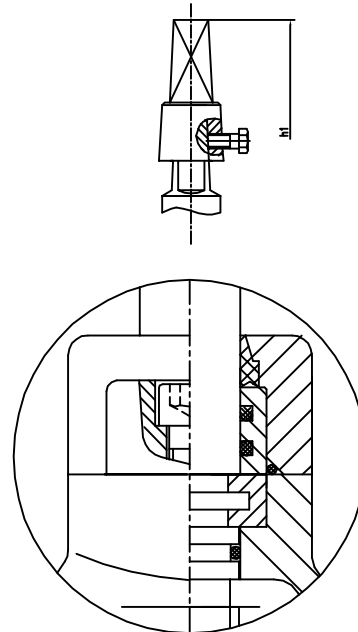
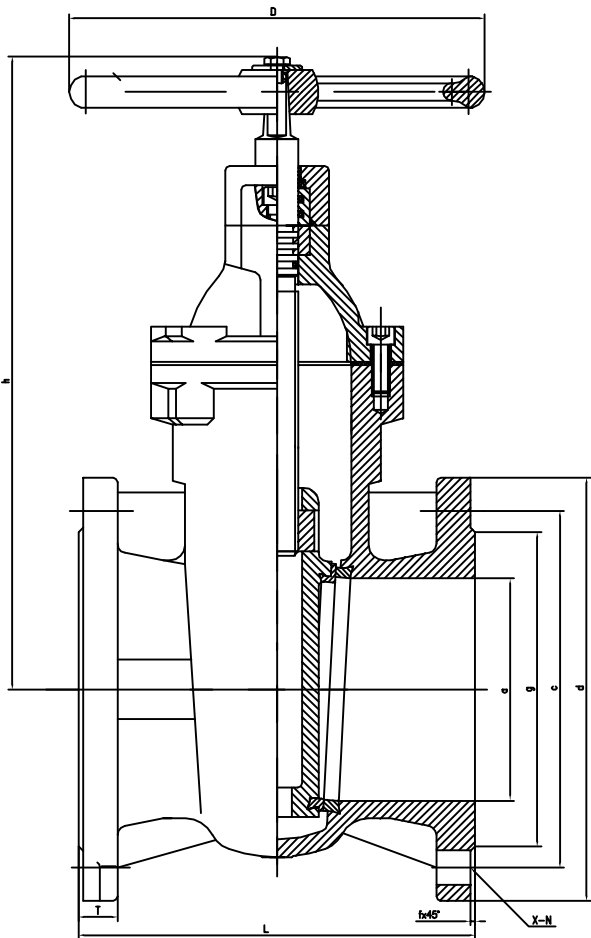

DIMENSIONS

DN	OUTLINE mm				END FLANGE BS PN10/16 mm								
	L	h	D	h1	a	d	c	x-n		T	g	f	
40	165	245	180	315	40	150	110	4- ϕ 19		19	84	3	
50	178	260	180	330	50	165	125	4- ϕ 19		19	99	3	
65	190	285	180	455	65	185	145	4- ϕ 19		19	118	3	
80	203	335	205	405	80	200	160	8- ϕ 19		19	132	3	
100	229	365	240	435	100	220	180	8- ϕ 19		19	156	3	
125	254	420	240	490	125	250	210	8- ϕ 19		19	184	3	
150	267	480	280	550	150	285	240	8- ϕ 23		19	211	3	
200	292	570	320	640	200	340	295	8- ϕ 23	12- ϕ 23	20	266	3	
250	330	670	360	740	250	405	350	355	12- ϕ 23	12- ϕ 28	22	319	3
300	356	775	450	845	300	460	400	410	12- ϕ 23	12- ϕ 28	24.5	370	4